

**Level Crossing Product Supply for Sri Lanka Railways
The Level Crossing Protection Equipment of Alkmaar Railway Signalling Systems**

The Netherlands has over 2,700 protected level crossings. Almost all of these level crossings are equipped with Alkmaar Railway Signalling Systems level crossing protection equipment. From Andreas cross, and barrier pole to a complete AHOB installation. Alkmaar Railway Signalling Systems has the lead in level crossing protection equipment. With more than 125 years of rail experience, we offer great quality and service in our products that customer can rely on.



Everything as you like it

Alkmaar Railway Signalling Systems has a wide range of level crossing protection equipment. You can consult us for:

- Barrier signs
- Waiting signs
- Barrier poles
- Assembled AHOB posts
- Barrier mechanisms
- LED XC signals
- Andreas crosses
- Electronic warning bells
- Aluminum crossing barriers with LED lights
- Wooden crossing barriers

Our Two Lamp Flasher Unit (Existing SLR Type) – is an existing Level Crossing Road Signal type currently in use by the Sri Lanka Railways. All dimensions and specifications are in accordance to the SLR’s requirement. The signal body is built and assembled in Holland.

The photo above shows the Sri Lanka Type Level Crossing Road Signals and the mechanical drawing below illustrates the dimensions and assembly overview of the Signal.

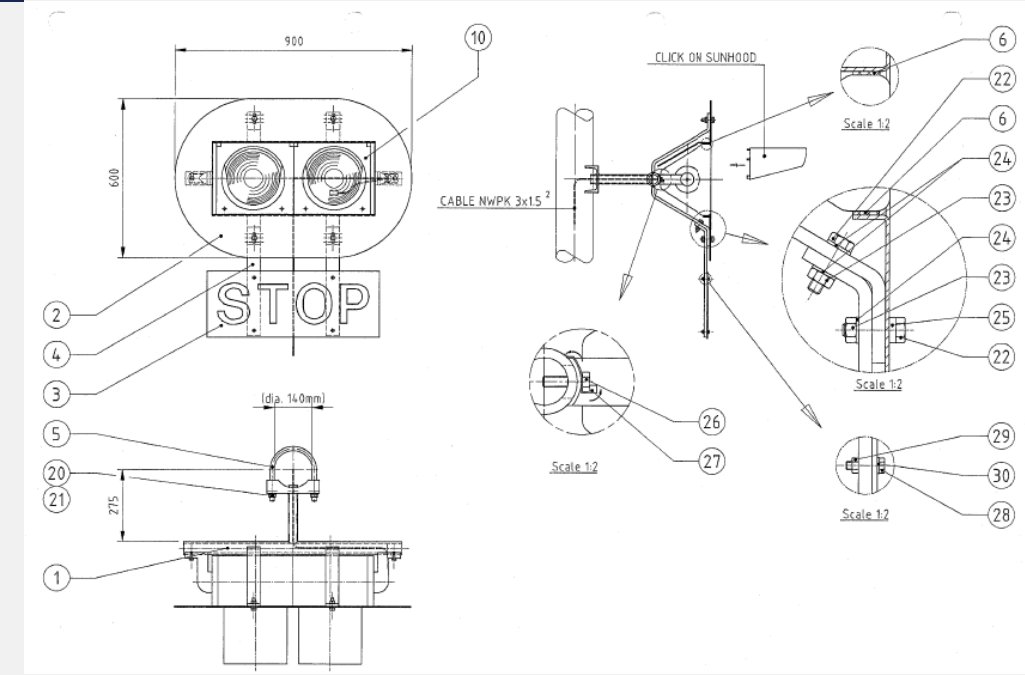

Australian Custom Modified Type

Our Australian Custom Modified Type Level Crossing Road Signal is a custom modified road signal, fulfilling all dimensions and specifications as per the Sri Lanka Railways' Specification & Drg No: CS 450/97.

The signal body is an existing road type incandescent lamp signal that is widely used in Australia. This signal has evolved from over twenty five years of experience in road signal lantern design and production. Through the use of thermoplastic or die cast material selection and production control, a long life and durability of the lanterns is ensured.

Our Australian Custom Modified Type Level Crossing Road Signal offers:

- Australian Standard AS/NZS2144:2002 extended range performance
- Proven performance
- Modern durable thermoplastic materials
- Structural strength
- Quality reflectors
- Pre-focused lamp sockets
- Easy access for lamp change and reflector cleaning
- Dual hinging doors
- Design suitable for all weather and operating environments
- Injection molded, or aluminum pressure die cast, modular housing components
- Wide range of accessories



*A different type of background plate is shown in the picture above. A background plate complying to SLR Drg No. CS 450/97 will be supplied

Would you like
to know more about
the services, products or projects of
Alkmaar Railway Signalling?

Please contact our Sales Department
by sending an email to
info@alkmaar-rs.com
or go to our website
www.alkmaar-rs.com.